

**DROP-OFF ADJACENT TO TRAVELED WAY**

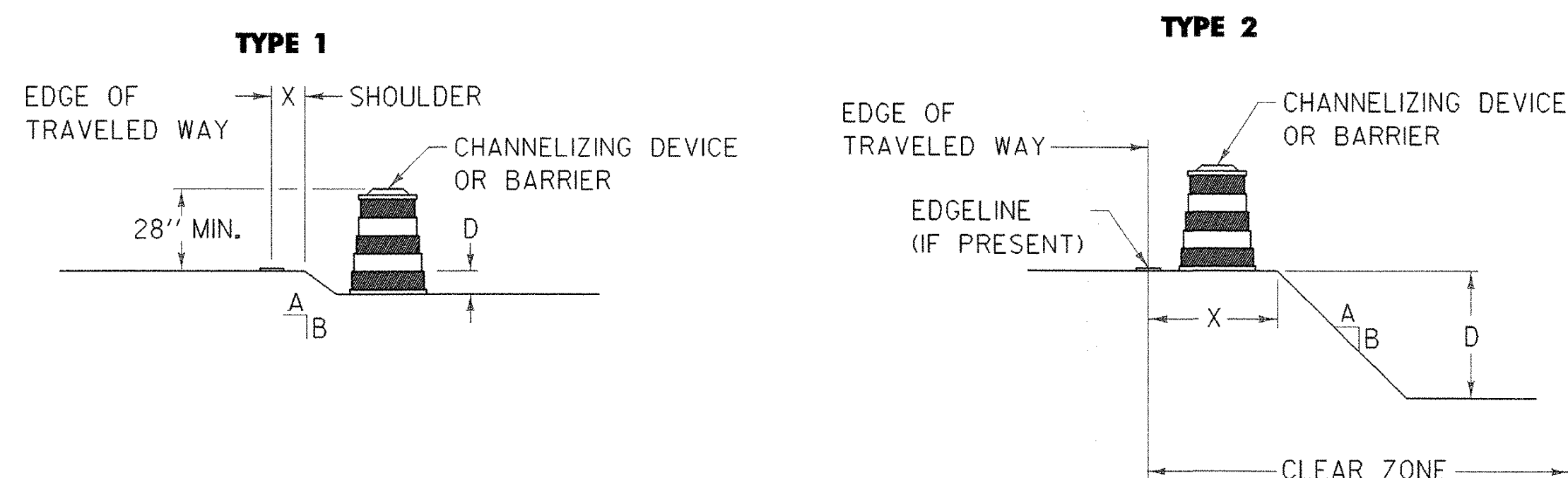

**NOTES:**

1. CHANNELIZING DEVICES OR BARRIER SHOULD BE PLACED TO MAXIMIZE THE WIDTH OF THE TRAVELED WAY.
2. FOR SPECIFIC REQUIREMENTS USE CHART "A".
3. IF THE DROP-OFF REQUIRES CHANNELIZING DEVICES TO REMAIN IN PLACE OVERNIGHT THEN "LOW SHOULDER" (W8-9) OR "SHOULDER DROP OFF" (W8-9A) SIGNS SHOULD BE INSTALLED.

**DROP-OFF BETWEEN ADJACENT TRAVELED LANE**

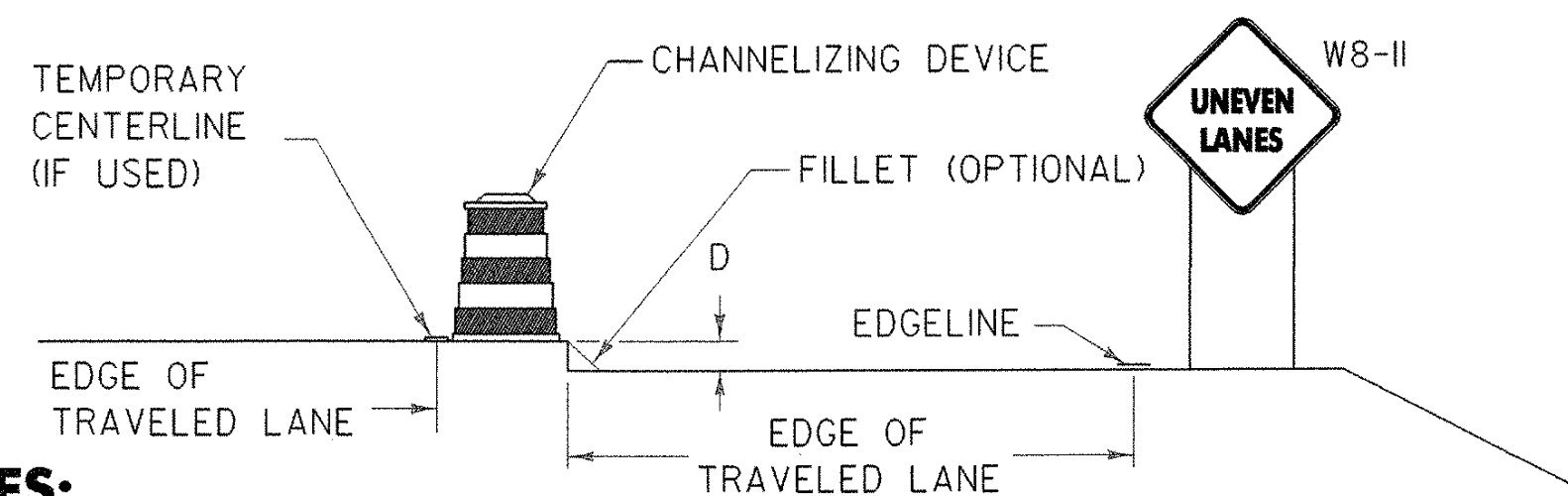

**NOTES:**

1. WHENEVER A LONGITUDINAL DROP-OFF BETWEEN ADJACENT TRAVELED LANES IS TO BE LEFT OVERNIGHT THEN "UNEVEN LANES" (W8-II) SIGNS AND CHANNELIZING DEVICES SHOULD BE INSTALLED.
2. IF REQUIRED, THE CHANNELIZING DEVICES USED SHALL BE THOSE WHICH MAXIMIZE THE TRAVELED LANE (I.E. CONES, VERTICAL PANELS OR TUBULAR MARKERS).
3. A BITUMINOUS CONCRETE FILLET WITH A 1.5:1 SLOPE MAY BE USED IN PLACE OF CHANNELIZING DEVICES, HOWEVER THE "UNEVEN LANES" (W8-II) SIGNS SHOULD BE INSTALLED REGARDLESS.
4. FOR SPECIFIC REQUIREMENTS USE CHART "A".

**DROP-OFF BEYOND SHOULDER OR CURB**

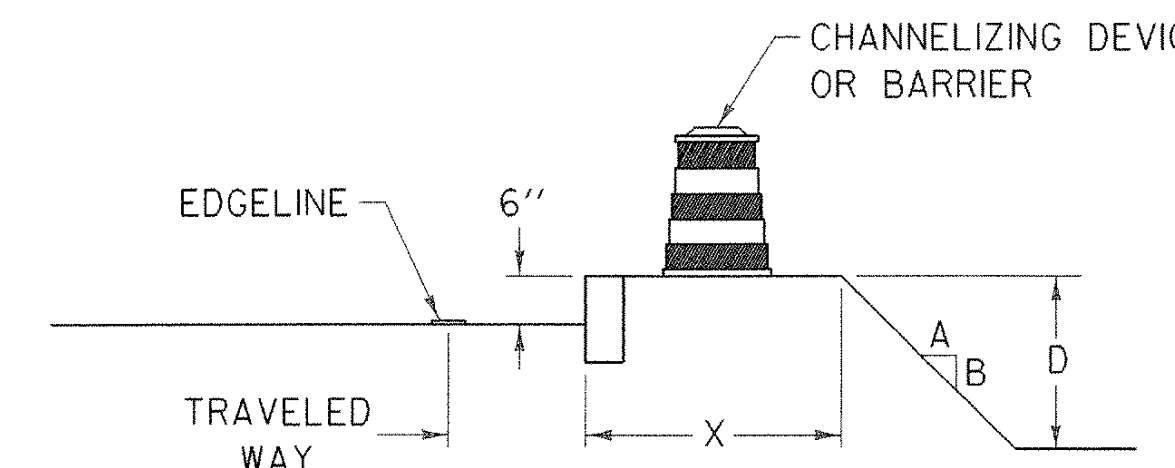

**NOTES:**

1. CHANNELIZING DEVICES OR BARRIER SHOULD BE PLACED TO MAXIMIZE THE WIDTH OF THE TRAVELED WAY.
2. FOR SPECIFIC REQUIREMENTS USE CHART "A" OR "B" AS APPLICABLE.

**CHART "A"**

**ALL SPEEDS WITH NO CURB**

X (FEET)	DROP (D) (INCHES)	A/B SLOPE	DEVICE REQUIRED
0 TO 4'	LESS THAN 2"	ANY	NONE
	2" TO 6"	1.5:1 OR FLATTER	NONE
		STEEPER THAN 1.5:1	CHANNELIZING DEVICE
GREATER THAN 6"	3:1 OR FLATTER	3:1 OR FLATTER	NONE
		STEEPER THAN 3:1	BARRIER/CHANNELIZING DEVICE
4' TO 10'	LESS THAN 6"	ANY	NONE
	6" TO 12"	3:1 OR FLATTER	NONE
		STEEPER THAN 3:1	BARRIER/CHANNELIZING DEVICE
GREATER THAN 12"	3:1 OR FLATTER	3:1 OR FLATTER	NONE
		STEEPER THAN 3:1	BARRIER/CHANNELIZING DEVICE
10' TO CZ	LESS THAN OR EQUAL TO 12"	ANY	NONE
	GREATER THAN 12"	3:1 OR FLATTER	NONE
		STEEPER THAN 3:1	BARRIER

**NOTES:**

1. THE MINIMUM CLEAR ZONE FOR FREEWAYS IS TO BE DETERMINED PER THE CURRENT "AMERICAN ASSOCIATION OF STATE HIGHWAY TRANSPORTATION OFFICIALS" (AASHTO) ROADSIDE DESIGN GUIDE. ALL OTHER HIGHWAYS WILL BE DETERMINED PER THE CURRENT "VERMONT STATE STANDARDS" BOOK.
2. CHANNELIZING DEVICES MAY BE USED INSTEAD OF BARRIER FOR SHORT TERM (ONE-DAY) OPERATIONS.
3. ON BORDERLINE CONDITIONS, THE ENGINEER SHOULD DETERMINE WHICH TREATMENT IS ADEQUATE FOR THE EXISTING CONDITIONS.

**CHART "B"**

**40 MPH OR LESS WITH CURB**

X (FEET)	DROP (D) (INCHES)	DEVICE REQUIRED
0-10'	LESS THAN OR EQUAL TO 12"	NONE
0-10'	GREATER THAN 12"	CHANNELIZING DEVICE
GREATER THAN 10'	ANY	NONE

**NOTES:**

1. USE THIS CHART FOR DROP-OFF BEYOND SHOULDER OR CURB.
2. USE THIS CHART FOR VERTICAL CURBS OF SIX INCHES OR GREATER. FOR LOWER OR MOUNTABLE CURBS USE CHART "A".
3. FOR CURBED SECTIONS WITH POSTED SPEED ABOVE 40 MPH, USE CHART "A".

**GENERAL NOTES:**

1. THESE CONDITIONS AND TREATMENTS ARE ONLY PART OF THE TRAFFIC CONTROL SYSTEM AND SHOULD BE USED IN ADDITION TO THE PROPER WORK ZONE SIGNING.
2. THE FOLLOWING ARE ACCEPTABLE CHANNELIZING DEVICES:
  - A. VERTICAL PANEL
  - B. TYPE I OR TYPE II BARRICADE
  - C. PLASTIC DRUM
  - \* D. CONE - WHERE APPLICABLE
  - E. TUBULAR MARKERS (MUTCD)

\* IF CHANNELIZING DEVICES ARE REQUIRED TO REMAIN IN PLACE DURING NIGHTTIME HOURS, CONES SHALL BE A MINIMUM OF 36 INCHES HIGH.
3. WHERE BARRIER IS CALLED FOR, EITHER CONCRETE BARRIER (JERSEY SHAPE), STEEL BEAM GUARDRAIL OR OTHER FEDERAL HIGHWAY ADMINISTRATION (FHWA) APPROVED BARRIER MAY BE USED.
 

BARRIER ENDS FACING ONCOMING TRAFFIC SHALL BE TAPERED BEYOND THE CLEAR ZONE OR PROTECTED WITH AN APPROVED END TREATMENT DESIGNED FOR THE POSTED SPEED LIMIT OF THE ROADWAY.
4. CHANNELIZING DEVICE SPACING ALONG A LONGITUDINAL DROP-OFF (TANGENT) SHALL BE AS FOLLOWS:
 

TANGENT - CHANNELIZING DEVICES SHALL BE SPACED "2S" ("S" IS THE POSTED SPEED LIMIT IN FEET) APART.
5. "LOW SHOULDER" (W8-9), "SHOULDER DROP OFF" (W8-9A) OR "UNEVEN LANES" (W8-II) SIGNS, WHEN USED, SHOULD BEGIN PRIOR TO THE DROP-OFF CONDITION AND SHOULD BE REPEATED EVERY 1500 FEET.
6. USE CHART "A" FOR DROP OFFS CREATED BY PROJECT ACTIVITIES.

**OTHER STDS. REQUIRED: E-101, E-106, E-107, E-107A**

REVISIONS AND CORRECTIONS  
 SEPT. 20, 1993- ORIGINAL APPROVAL DATE  
 AUG. 18, 1995 - ADDED SHOULDER WARNING NOTE  
 DEC. 8, 2008 - GENERAL UPDATE  
 JUN. 8, 2009 - MINOR REVISIONS

APPROVED  
*Kevin A. Naashee*  
 HIGHWAY, SAFETY & DESIGN ENGINEER  
*Richard Schmidt*  
 DIRECTOR OF PROGRAM DEVELOPMENT  
*Mark D. Richter*  
 FEDERAL HIGHWAY ADMINISTRATION

**CONSTRUCTION ZONE  
 LONGITUDINAL DROP OFFS**



**STANDARD  
 E-108**